

4-PAD VACUUM LIFTER

4-PAD VACUUM LIFTER AT A GLANCE

- Lifting Capacity- 1,000kg/2,200lbs
- 4 suction pads - 19 11/16" x 11 13/16"
- Pneumatic Tilting 0-90°
- Continuous vacuum pump powered by compressed air
- Gauge with graduated and colored scale to monitor degree of vacuum
- Powerful and quiet vacuum generator with reduced air consumption of 26 gal/min
- Operating pressure 4/6 bar
- Gaskets made of rubberized fabric suitable for smooth, flamed, and bush-hammered surfaces
- High-limit yielding steel suction pads
- Exclude pads by means of a tap
- No-falling non-return valve for vacuum
- Sliding valve to control gripping and releasing of the material with safety block against involuntary maneuvers
- Aluminum safety tank for vacuum reserve and condensation discharge valve, to guarantee gripping even when there is loss of power
- Acoustic and visual alarm system which automatically signals a low vacuum degree. It works autonomously by means of rechargeable batteries and it is supplied with the appropriate battery charger at 220 volt
- Maneuvering handle with pushbutton control unit holder

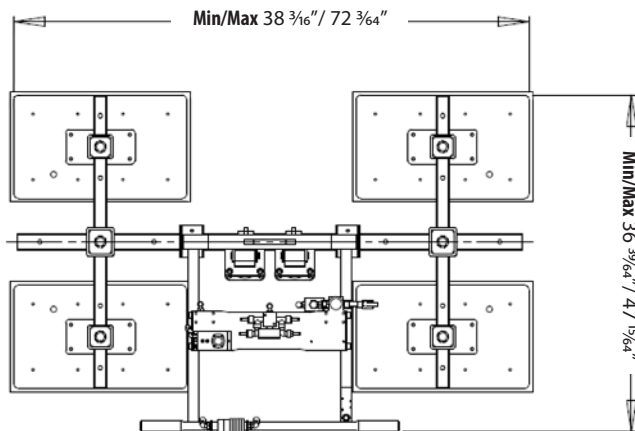
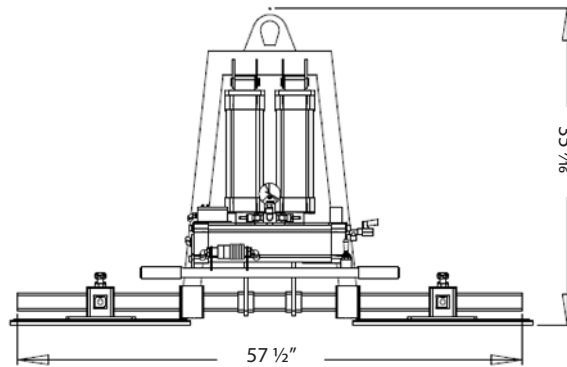

101 PREMIER DRIVE
ORION TOWNSHIP, MI 48359

855-847-7330 TOLL FREE
248-791-3060
BACASYSTEMS.COM